



Standard Operating

1	Important Information	2
1.1	Instructions on Documentation	2
1.2	Safekeeping of the Documentation	2
1.3	Used Symbols	2
1.4	Qualified Staff	2
1.5	General Safety Instructions	3
2	Overview of Screw Jacks	4
3	Design of the Screw Jack C-Series Type N	5
4	Design of Screw Jack C-Series Type R	6
5	Assembly	7
5.1	General Assembly Instructions	7
5.2	Screw Jack with Limit Switch	10
5.3	Screw Jack with safety nut	11
6	Commissioning	12
7	Maintenance	12
7.1	Trapezoidal Thread	12
7.2	Ball Screw	13
7.3	SLA pivot bearing mounting column	14
7.4	Lubricants and Fill Quantities	14
8	Equipment failure	17
9	Manufacturer's Declaration	18

1 Important Information

This chapter contains important information on the safe handling of the product and this operating manual.

1.1 Instructions on Documentation

The following instructions will guide you through the entire documentation.

We assume no liability for damages resulting from non-compliance with this operating manual.

Forward this operating manual to the plant operator so that it is available if needed.

1.2 Safekeeping of the Documentation

Keep this operating manual and all other applicable documents safe so that they are available if needed.

1.3 Used Symbols



Information

Instructions and information on the operation of the Screw Jacks.



Attention!

Non-compliance may result in material damage and impair the operation of the gear unit.



Warning!

Safety instruction: non-compliance may result in serious or fatal injuries.



QR Barcode

Provides a direct link to the products on our website. Compatible with QR barcode scanner apps for all Android, Apple, and Windows smartphones/tablets.

1.4 Qualified Staff



Qualified staff according to this operating manual refers to specialists who are familiar with the installation, assembly, commissioning, and operation of the worm gear screw jacks and the hazards involved and who possess the necessary capabilities based on their specialist training and knowledge of the applicable standards.

The following warnings, preventive measures, and instructions are intended to guarantee your safety and avoid damage to the lifting gear or the components connected to it. This chapter contains warnings and instructions that generally apply to the handling of the lifting gear.



Intended Use:

The Screw jacks C-Series are intended only to carry out lifting, lowering, tilting, and feeding motions.

Please find lifting capacities in our catalog or at www.neff-gewindetriebe.de. Any other use is considered misuse. The manufacturer assumes no liability for any damage resulting from misuse.

If the device is installed in machines or plants, commissioning is prohibited until it is determined that it complies with the EC machinery directive.



Attention!

Requirement according to the German accident prevention regulations VBG14 / VBG 70:

If worm gear screw jacks are operated in theatre stages (VBG 70), lifting platforms (VBG 14), or lifting equipment where there is a danger to persons, we generally recommend using a safety nut for fall protection.



Attention!

This operating manual must be kept close to the device and be easily accessible and available to all users.



Attention!

Risk of damage to the lifting gear resulting from storage and transport.

Correct storage, installation, and assembly as well as diligent operation and maintenance are prerequisites for the trouble-free and safe operation of the worm gear screw jacks.

The worm gear screw jack must be protected against mechanical impacts and vibrations during transport and storage.



Warning!

Work on live components:

E.g., the installation of limit switches or a drive unit must only be carried out by trained electricians.

2 Overview of Screw Jacks



Description of Screw Jacks:

Neff Screw Jacks C-Series are used for applications where precise lifting, lowering, tilting, and feeding motions are required. The classic gear housing allows the mounting of a motor, gearbox, or encoder. All models are designed to cater for pressure and tensile loads as well as position-independent operation.

2 different movement principles have to be distinguished:

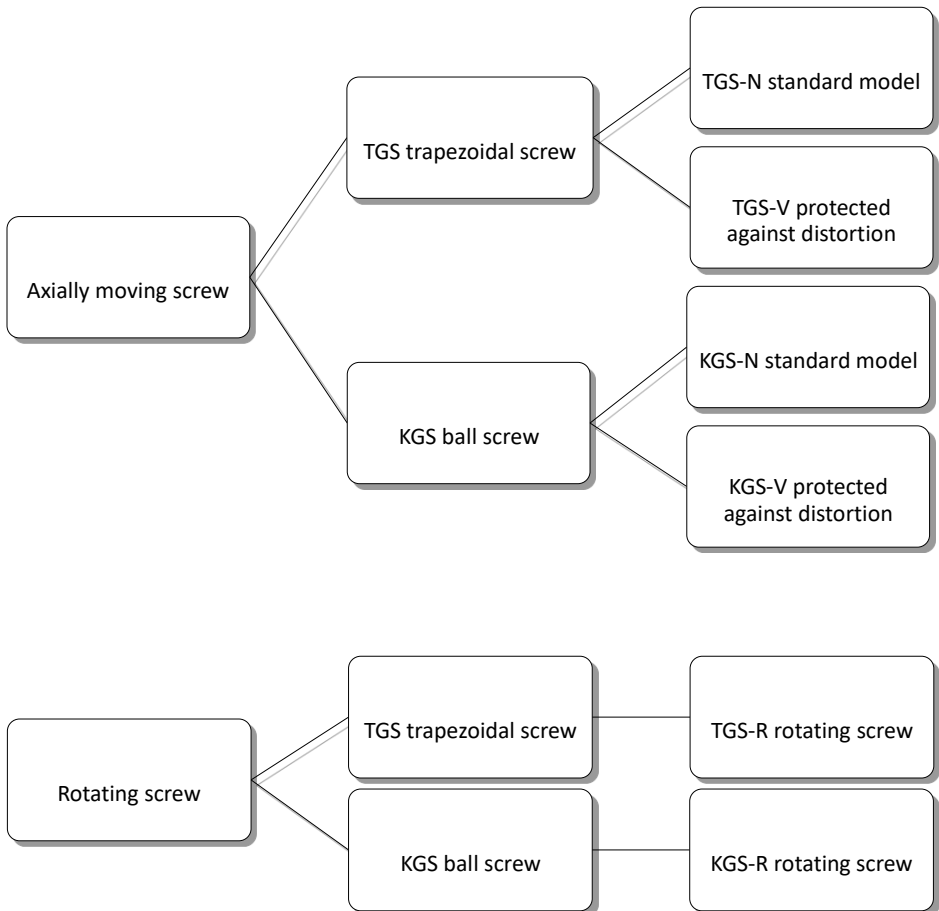

3 Design of the Screw Jack C-Series Type N

Version C-Series with trapezoidal threaded screw type N (axial moving spindle, not secured against torsion)

Position	Designation
1	Housing
2	Intermediate flange
3	Bearing cover
4	Worm gear
5	Worm gear shaft
6	Cover tube
7	Trapezoidal screw
8	Axial grooved ball bearing
9	Bevel bearing
10	O-ring
11	Radial-shaft seal ring DIN 3760
12	Snap ring DIN 471
13	Radial-shaft seal ring DIN 3760
14	Fitted key DIN 6885
15	Grub screw
16	Shim ring
17	O-ring
18	Bolt
19	Cover tube end cap

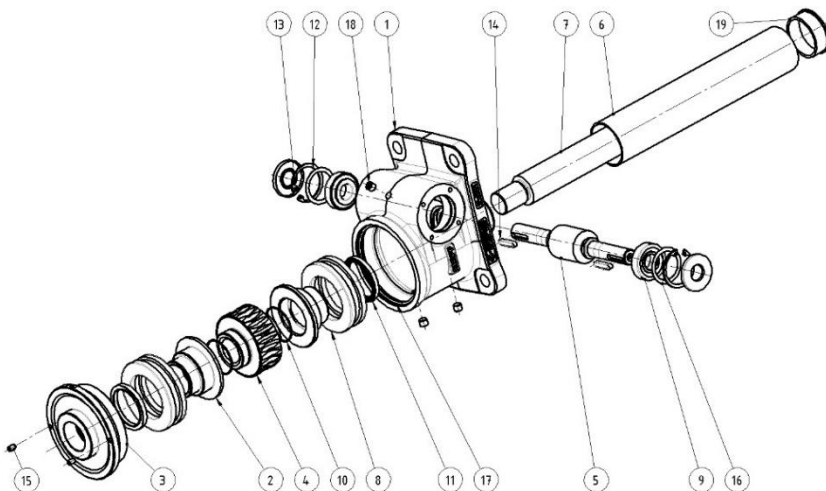

4 Design of Screw Jack C-Series Type R

Version SHG C-Series with trapezoidal threaded spindle type R (rotating screw)

Position	Designation
1	Housing
2	R-bush
3	Bearing cover
4	Worm gear
5	Worm gear shaft
6	Trapezoidal screw
7	Axial grooved ball bearing
8	Bevel bearing
9	Snap ring DIN 471
10	Radial-shaft seal ring DIN 3760
11	Fitted key DIN 6885
12	Grub screw
13	KMT nut
14	Grooved ball bearing or taper roller bearing
15	Radial-shaft seal ring DIN 3760
16	Snap ring DIN 471
17	Fitted key DIN 6885
18	Shim ring DIN 988
19	O-ring DIN 3601
20	Bolt
21	O-ring DIN 3601
22	End cap
23	Trapezoidal nut

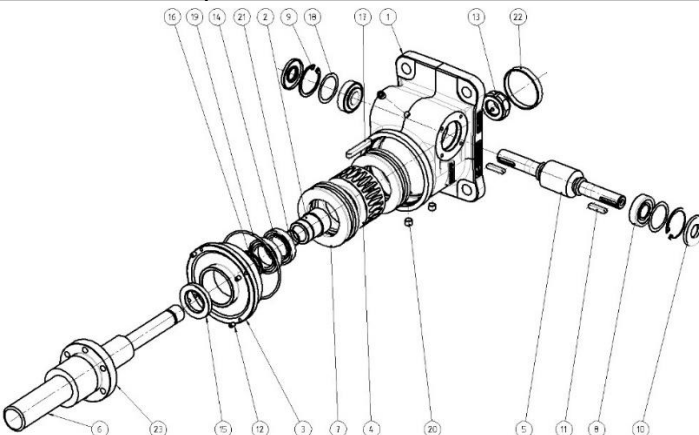

5 Assembly

5.1 General Assembly Instructions



The worm gear screw jack is fastened via the housing or other fastening components (mounting plates or card adapters, see QR code below). The housing always needs to be screwed to a machined surface (not to rolled steel profiles or similar) to avoid misalignment or noise.

Depending on the respective application, the worm gear screw jack and the screw have to be precisely aligned at a right angle or in parallel to the machine component and tightened during assembly.

The tolerances of the four assembly sides correspond to the DIN ISO 2768-mH standard.

Size	C3	C5	C15	C20	C30	C50
Bolts (min. 8.8)	M12	M16	M20	M27	M33	M45
Length of engagement	16	24	30	40	45	60
Max. torque in Nm	89	215	420	1070	1950	5000

The torques mentioned in the table are only rough and nonbinding guidelines – see VDI 2230.



Lateral forces must be absorbed by suitable guide rails; otherwise, the device lifecycle would be shortened.



Attention!

The lubrication nipples must always be accessible during operation.



Attention!

Do not hammer the shaft end or the screw when aligning the worm gear screw jack.

QR barcode to Neff fastenings:

QR barcode to Neff attachments:



Parallel mounting of several Screw Jacks

Info:

A Screw Jack is already installed and fixed as described in Chapter 4!



1. Put the second Screw Jack in the foreseen position, but do not fasten it yet.
2. When running with rotating spindles, bring the nuts to the same position.
3. Slide the coupling or cardan shaft onto the worm shaft of the already mounted Screw Jack.
4. Slide the coupling or cardan shaft onto the worm shaft of the second Screw Jack.
5. Fixing the Screw Jack.
6. Repeat steps 1-5 for further transmission units.



Attention!

Check the direction of rotation of all lifting elements before installation.



Attention!

To compensate for misalignment of the spindle lifting gears, torsional elastic couplings, cardan shafts or cardan joint shafts must be used.



Attention!

During the run-in phase, observe the lubricating film and spindle temperature. Rapid dry running (with ball screw spindles and strong running noise) and increased temperature despite compliance with the duty cycle and permissible power indicate inadmissible lateral forces.

QR-Barcode for Neff couplings:

QR-

Barcode for Neff Cardan Shaft:



5.2 Screw Jack with Limit Switch



The limit switches are preset by NEFF. The customer must check the stroke end positions and set the limit switches!

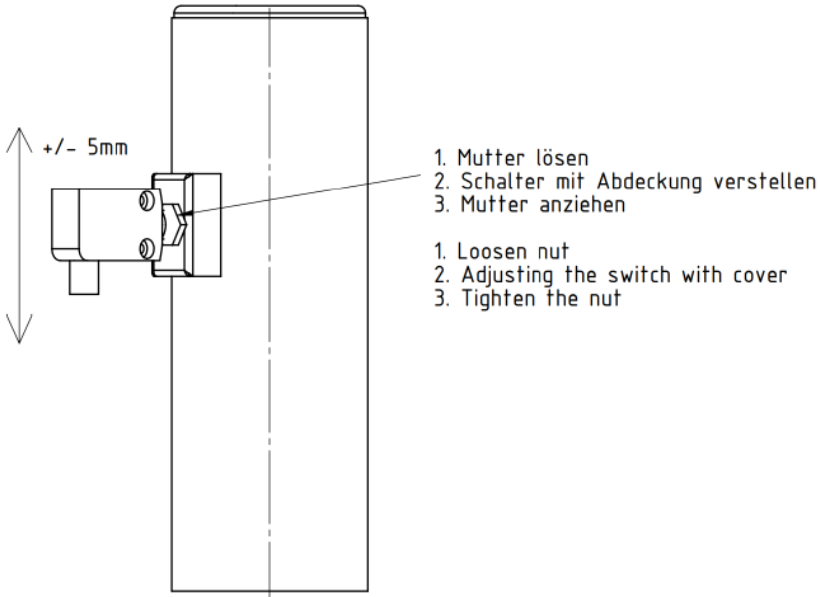

Montagevideo / Assembly video



5.3 Screw Jack with safety nut

Safety nut acc. to VBG14 or VBG70 requirements only will be available on request.

If nothing else is specified, our standard safety catch nuts will be delivered.

In this connection, the technical data of the safety catch nut always shall be counter-checked against the existing requirements.

❶ Standard safety nut with trapezoidal or slide thread:

The safety nut will rotate without axial load and thus without any wear with the running nut. At increased wear (trapezoidal or slide thread design), the distance X between both nuts will decrease.

At a reduction of 25% of the distance X , the running nut shall be replaced. For this purpose, the measure X shall be recorded during commissioning and periodically be checked by a maintenance plan.

In case of a rupture of the thread turning off the running nut due to increased wear or excessive load, the safety nut will pick up the supported load.

Rotating Version:

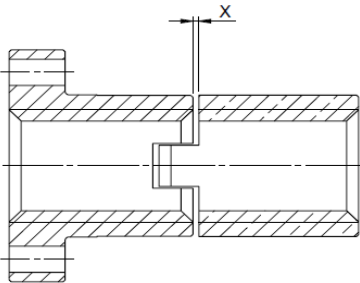

Standing version: Depending on the version

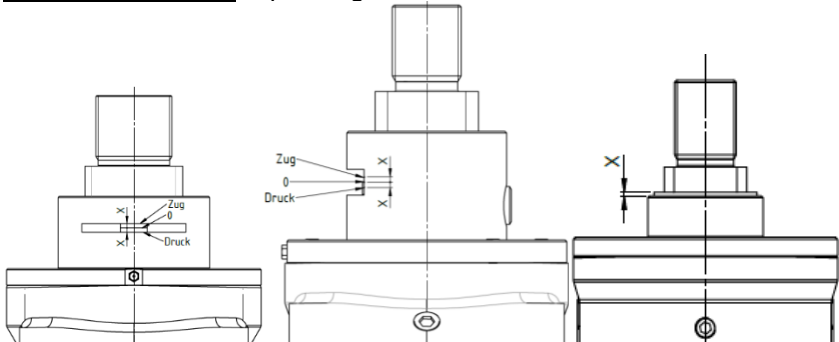

ⓘ Standard safety nut with ball thread:

Safety nuts for ball thread nuts always will be manufactured individually by the intended use and the ball size.

Normally the ball thread unit will get locked in case of failure and call for attention by an excessive power input.

The safety distance X always will be defined by the size of the ball. An optical wear control only will be possible at ball rupture or destruction of the deflection pieces.

For this reason, we recommend the integration of torque supervision in motor control.

The safety nuts will be dimensioned by the maximum static load of the ball thread nut and will pick up the load at the failure of the nut.

6 Commissioning



Attention!

Screw Jack oil filled and with vent valve: Install enclosed vent valve before operation.

Note install position, The vent valve must be mounted above the oil level.



Attention!

Check the operation of the limit switch. If possible, start the worm gear screw jack without any load and increase the load slowly.

During commissioning, continuously check the operating temperature, power consumption of the motor, and the screw contact pattern.

7 Maintenance



7.1 Trapezoidal Thread

• **For trapezoidal threads**, lubricate the lockers regularly using the attached grease nipple on the bearing cover. Prevent dryness during running!

• **In the case of the VK version**, the sliding block must be lubricated regularly. This is done via the two grease nipples on the square protection tube. Prevent dryness during running! Recommendation for the interval: 200-600 operating hours Relubricate about 1 ml per 10 mm edge length of the square tube per grease nipple (depending on the application).

- **After about 5 operating hours** of commissioning: Retightening all fastening bolts must be done.
- **After about 200 operating hours or 1 year** (in case of difficult operating conditions at shorter intervals):
Check the spindle nut for signs of wear and tear. Clean the spindle of old grease and lubricate it with new grease.
- **NEFF Screw Jacks are lubricated for service life** if thermal and mechanical limit values are complied with.
- **Disassembly of the bearing cover:**
 1. Loosening the grub screws on the bearing cover
 2. Unscrew the spindle (possibly remove the spindle guard).
 3. Unscrew the bearing cover.
 4. Removing the old grease.
 5. Refilling with new grease.
 6. Strong application of the bearing cover (10 times the normal application force).
 7. Loosen the bearing cover again.
 8. Put on the bearing cover and secure it with grub screws.

7.2 Ball Screw

- **All figures are only indicative** and are partly based on experience. It is therefore essential to check the ball screw regularly and to pay attention to signs of insufficient lubrication, such as dry spindle or high-fat loss!
- **For ball screw spindles**, the guideline value applies to relubricate approximately every 200-600 operating hours, approximately 1 ml per 10 mm spindle diameter.
- **In the case of the VK version**, the sliding block must be lubricated regularly. This is done via the two grease nipples on the square tube. Prevent dry running! Recommendation for the interval: 200-600 operating hours Relubricate about 1 ml per 10 mm edge length of the square tube per grease nipple (depending on the application).
- **After about 5 operating hours** of commissioning: Retightening of all fastening screws.

- **For ball screw spindles**, the guideline applies approximately every 200 hours, re-lubricate 1ml per 10mm spindle diameter. In the N-version, the ball screw is lubricated for life.

- **NEFF screw jacks are lubricated for service life** if thermal and mechanical limit values are complied with.

7.3 SLA pivot bearing mounting column

- **In the case of the VK version**, the sliding block must be lubricated regularly. This is done via the two grease nipples on the square tube. Prevent dry running! Recommendation for the interval: 200-600 operating hours Relubricate about 1 ml per 10 mm edge length of the square tube per grease nipple (depending on the application)



Attention!

When assembling the bearing cover, make sure it fits smoothly and that there is no axial play.



Attention!

Change the screw nut if the axial play exceeds 1/4 of the thread pitch (trapezoidal thread).

7.4 Lubricants and Fill Quantities



Types of factory grease:

Screw Jack / Trapezoidal screw:

NEFF GREASE 000 / NEFF GREASE 2

Safety data sheet NEFF GREASE 000 / 2:



Ball screw:

NEFF GREASE 2/3

Safety data sheet NEFF
GREASE 2/3:



Screw Jacks with oil filling:

AVILUB GEAR RSX-F 320, interchangeable with CLP mineral-based oil gear oils of viscosity class 320.

• Oil change gearbox:

9. Loosening the plug screw on the screw shaft
10. Loosening the lower locking screw over the housing base plate
11. Drain the oil completely.
12. Glue the plug screw over the base plate with a threaded seal.
13. Fill in new oil via the bore on the screw shaft and glue in the plug screw



Screw jacks with synthetic oil filling:

AVIA SYNTOGEAR XP-460, interchangeable with CLP-PAO-based synthetic OIL of viscosity class 460.

• Oil change gearbox:

14. Loosening the plug screw on the screw shaft
15. Loosening the lower locking screw over the housing base plate
16. Drain the oil completely.
17. Glue the plug screw over the base plate with a threaded seal.
18. Fill in new oil via the bore on the screw shaft and glue in the plug screw

Fill quantities:

Type	C3	C5	C15	C20	C30	C50
Fill quantities grease in (gr.)	400	500	800	900	1150	2200
Fill quantities oil in (ml.)	400	500	800	900	1150	2200



Screw Jack C-Series

In addition to our factory lubricants, other equivalent brand lubricants may also be used.

This only applies if they are compared to the data sheets of the above manufacturers.



Too much grease increases friction and therefore causes an increase in temperature. There is enough lubricant when a small amount of grease begins to exit at the sealing lips.

8 Equipment failure



Service: Should malfunctions occur during operation, first try to identify the manner of the malfunction with the table below and repair it. If it is a malfunction you can't repair, please contact our technical service (see last page).

Malfunction	Cause	Remedy
Unusual, constant running noises.	<ul style="list-style-type: none"> ➤ Rolling/grinding: Bearing damage ➤ Tapping: Irregularity in gearing 	Check grease fill level. Consult the technical service.
Unusual, irregular running noises.	Foreign objects in the grease.	Check grease fill level. Stop driving. Consult the technical service.
Unusually high temperature at the housing.	<ul style="list-style-type: none"> ➤ Not enough grease. ➤ Defective gearing or bearing. 	Check and correct grease filling. Consult the technical service.
Grease or oil exists at the shaft seal ring.	Defective sealing.	Consult the technical service.
Grease or oil exists at the shaft seal ring and the screw.	Too much grease in the gear.	Check and correct the grease fill level. Consult the technical service.
The trapezoidal screw quickly runs dry.	Assembly fault: Impermissible lateral forces.	Repair assembly fault. Consult the technical service.
The worm gear shaft does not turn, or the screw turns but does not move although the worm gear shaft is turned.	The connection between the shaft and the hub or the gearing is broken.	Have the gear repaired.

9 Manufacturer's Declaration

We hereby declare that the following product:

Screw Jack, version M-J / MH-JH
with trapezoidal screws or ball screws
model N, R or V
in the sizes
C3, C5, C15, C20, C30, C50
for lifting and lowering loads

was manufactured in accordance with the EC machinery directive 2006/42/EC annex II B on incomplete machinery.

This incomplete machinery must not be commissioned until the machine it is to be incorporated in has been declared to comply with the provisions of the EC machinery directive, the harmonized standards, European standards or the applicable national standards.

The manufacturer undertakes to forward the documentation on the incomplete machinery to national authorities on request. The technical documentation was created according to annex VII B.

Person responsible for documentation:

Andreas Ries, Director of quality management

Address of the person responsible for documentation:

Neff Gewindetriebe GmbH
Karl-Benz-Str. 24
71093 Weil im Schönbuch
Germany

The following harmonized standards have been applied:

DIN EN ISO 12100-1 Safety of machinery – Basic concepts, general principles for design, part 1:
Basic terminology, methodology

DIN EN ISO 12100-2 Safety of machinery – Basic concepts, general principles for design, part 2:
Technical principles and specifications

The following national standards, guidelines and specifications have been applied:

BGV D8 Accident prevention regulations for hoist gears, lifting and towing equipment

Neff Gewindetriebe GmbH
Karl-Benz-Str. 24
71093 Weil im Schönbuch
+49(0)7157/53890-0

