

# Endenbearbeitung für Loslager/Festlager

## Form D, F

Die Art der Lagerung beeinflusst die Steifigkeit des gesamten Gewindetribs ebenso wie das Drehschwingungs- und Knickverhalten der Gewindespindel. Entsprechend den verschiedenen Lagerungsarten werden die erforderlichen Endenbearbeitungen durchgeführt.

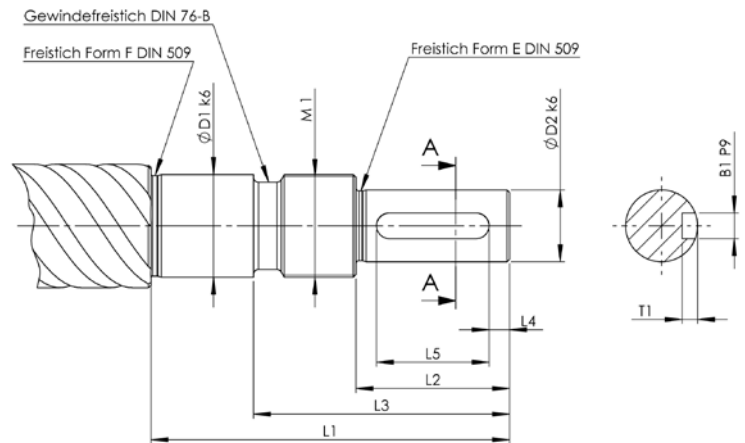

Form D	Abmessungen [mm]									Lager
TGS/GGS/KGS	D <sub>1</sub>	D <sub>2</sub>	L <sub>1</sub>	L <sub>2</sub>	L <sub>3</sub>	L <sub>4</sub>	L <sub>5</sub>	M <sub>1</sub>	B <sub>1</sub> xT <sub>1</sub>	ZKLF...2RS
Gewinde-Kerndurchmesser d <sub>2</sub> > d <sub>1</sub>	12	9	55	20	32	2,5	16	M 12x1	3x1,8	1255
	15	11	58	23	35	3,5	16	M 15x1	4x2,5	1560
	20	14	70	30	44	4	22	M 20x1	5x3	2068
	25	19	82	40	57	6	28	M 25x1,5	6x3,5	2575
	30	24	92	50	67	7	36	M 30x1,5	8x4	3080

Form F	Abmessungen [mm]									Lager
TGS/GGS/KGS	D <sub>1</sub>	D <sub>2</sub>	L <sub>1</sub>	L <sub>2</sub>	L <sub>3</sub>	L <sub>4</sub>	L <sub>5</sub>	M <sub>1</sub>	B <sub>1</sub> xT <sub>1</sub>	ZARN...LTN
Gewinde-Kerndurchmesser d <sub>2</sub> > d <sub>1</sub>	15	11	73	23	35	3,5	16	M 15x1	4x2,5	1545
	20	14	88	30	45	4	22	M 20x1	5x3	2052
	20	14	107	30	50	4	22	M 20x1	5x3	2062
	25	19	105	40	58	6	28	M 25x1,5	6x3,5	2557
	25	19	120	40	63	6	28	M 25x1,5	6x3,5	2572
	35	28	145	60	82	10	40	M 35x1,5	8x4	3585
	40	36	175	80	103	8,5	63	M 40x1,5	10x5	4090

# Endenbearbeitung für Loslager/Festlager

Form H, J, L

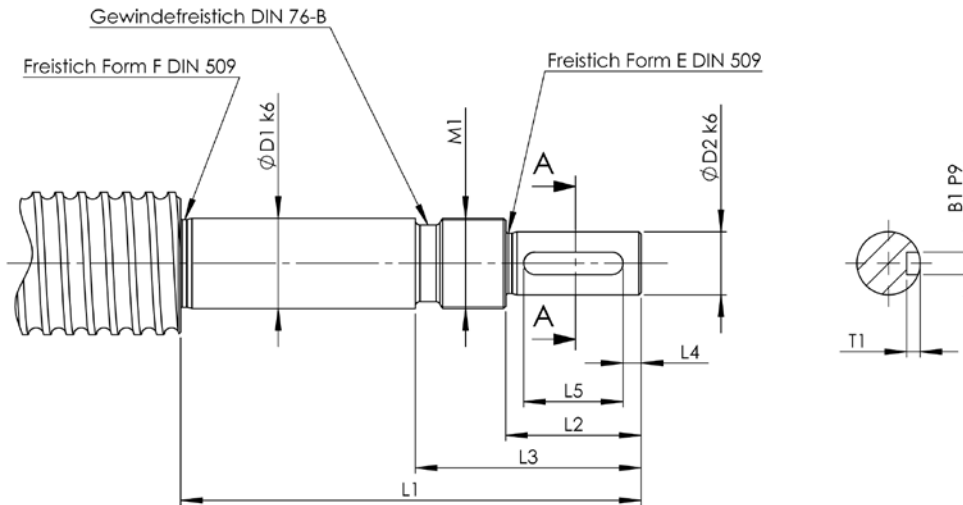

Form H TGS/GGS/KGS	Abmessungen [mm]									Lager ZARF...LTN
	D <sub>1</sub>	D <sub>2</sub>	L <sub>1</sub>	L <sub>2</sub>	L <sub>3</sub>	L <sub>4</sub>	L <sub>5</sub>	M <sub>1</sub>	B <sub>1</sub> xT <sub>1</sub>	
Gewinde-Kerndurchmesser d <sub>2</sub> > d <sub>1</sub>	15	11	85	23	35	3,5	16	M 15x1	4x2,5	1560
	20	14	102	30	44	4	22	M 20x1	5x3	2068
	20	14	122	30	49	4	22	M 20x1	5x3	2080
	25	19	120	40	57	6	28	M 25x1,5	6x3,5	2575
	25	19	135	40	63	6	28	M 25x1,5	6x3,5	2590
	35	28	160	60	81	10	40	M 35x1,5	8x4	35110
40	36	195	80	105	8,5	63	M 40x1,5	10x5	40115	

Form J TGS/GGS/KGS	Abmessungen [mm]									Lager FDX
	D <sub>1</sub>	D <sub>2</sub>	L <sub>1</sub>	L <sub>2</sub>	L <sub>3</sub>	L <sub>4</sub>	L <sub>5</sub>	M <sub>1</sub>	B <sub>1</sub> xT <sub>1</sub>	
Gewinde-Kerndurchmesser d <sub>2</sub> > d <sub>1</sub>	12	9	88	20	32	2,5	16	M 12x1	3x1,8	12
	15	11	92	23	35	3,5	16	M 15x1	4x2,5	15
	20	14	107	30	44	4	22	M 20x1	5x3	20
	25	19	122	40	57	6	28	M 25x1,5	6x3,5	25
	30	24	136	50	72	7	36	M 30x1,5	8x4	30
	40	36	182	80	102	8,5	63	M 40x1,5	10x5	40

Form L TGS/GGS/KGS	Abmessungen [mm]									Lager
	D <sub>1</sub>	D <sub>2</sub>	L <sub>1</sub>	L <sub>2</sub>	L <sub>3</sub>	L <sub>4</sub>	L <sub>5</sub>	M <sub>1</sub>	B <sub>1</sub> xT <sub>1</sub>	
Gewinde-Kerndurchmesser d <sub>2</sub> > d <sub>1</sub>	12	9	58	20	30	2,5	16	M 12x1	3x1,8	7201 BE RS
	15	11	73	23	33	3,5	16	M 15x1	4x2,5	7202 BE RS
	20	14	88	30	43	4	22	M 20x1	5x3	7204 BE RS
	25	19	120	40	55	6	28	M 25x1,5	6x3,5	7205 BE RS
	35	28	145	60	77	10	40	M 35x1,5	8x4	7207 BE RS
	40	36	175	80	103	8,5	63	M 40x1,5	10x5	7208 BE RS

Form A  
 Fase 2 x 45°: KGS von Ø 12 – 25 mm  
 Fase 3 x 45°: KGS von Ø 26 – 40 mm  
 Fase 4 x 45°: KGS von Ø 44 – 50 mm

# Endenbearbeitung für Loslager/Festlager

Form S, T, W

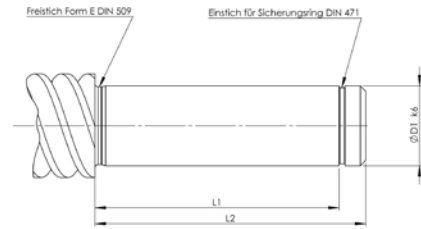

Form S TGS/GGS/KGS	Abmessungen [mm]			Distanzbuchse	Lager
	$D_1$	$L_1$	$L_2$		
Gewinde-Kerndurchmesser $d_2 > d_1$	12	40	45	18x12,1x24	6001 RS
	15	46	51	21x15,1x28	6002 RS
	20	53	58	27x20,1x29	6004 RS
	25	53	58	32x25,1x23	6205 RS
	30	60	68	40x30,1x28	6206 RS
	40	80	88	50x40,1x44	6208 RS
	55	102	110	65x55,1x60	6211 RS

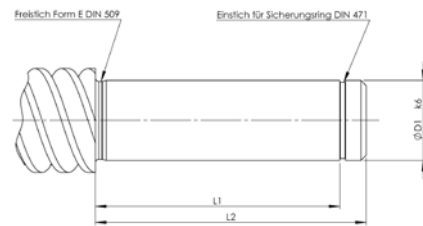

Form T TGS/GGS/KGS	Abmessungen [mm]			Innenring	Nadellager
	$D_1$	$L_1$	$L_2$		
Gewinde-Kerndurchmesser $d_2 > d_1$	12	40	45	2 IR 12x16x20	HK 1614 RS
	15	46	51	2 IR 15x20x23	HK 2018 RS
	20	53	58	2 LR 20x25x26,5	HK 2518 RS
	25	53	58	2 LR 25x30x26,5	HK 3018 RS
	30	60	68	2 LR 30x35x30	HK 3518 RS
	40	80	88	4 LR 40x45x20	HK 4518 RS

Form G: Spindelende gegläht, nach Angaben des Kunden.

Form K: Sonderanfertigung, nach Zeichnung des Kunden.

Form W TGS/GGS/KGS	Abmessungen [mm]			Lager
	$D_1$	$L_1$	$L_2$	
Gewinde-Kerndurchmesser $d_2 > d_1$	12	8	12	6001 RS
	15	9	13	6002 RS
	20	12	16	6004 RS
	25	15	20	6205 RS
	30	16	21	6206 RS
	40	18	25	6208 RS
55	21	29	6211 RS	

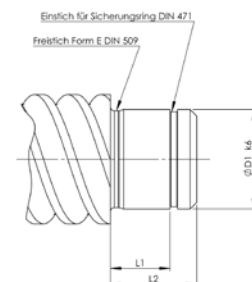

# Endenbearbeitung

Form FK - FF - BK - BF

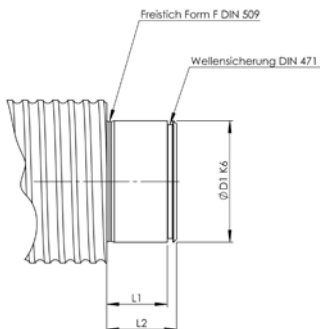
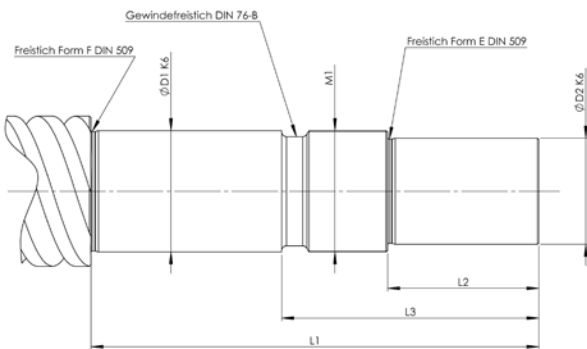
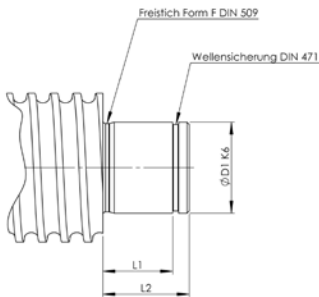
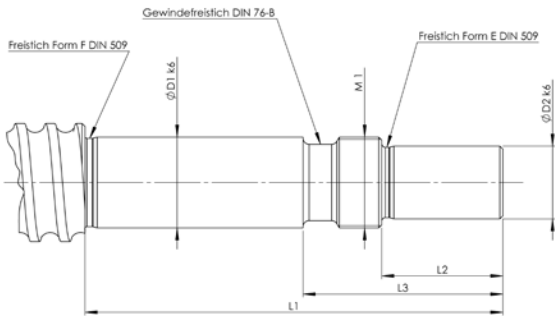

Bezeichnung	$\varnothing D_{1 k6}$	$\varnothing D_{2 k6}$	$L_1$	$L_2$	$L_3$	M1
FK 6	6	4	38	8	16	M6x0,75
FK 8	8	6	44	9	19	M8x1
FK 10	10	8	51	15	26	M10x1
FK 12	12	10	51	15	26	M12x1
FK 15	15	12	69	20	33	M15x1
FK 20	20	17	89	25	42	M20x1
FK 25	25	20	106	30	50	M25x1,5
FK 30	30	25	110	38	63	M30x1,5

Bezeichnung	$\varnothing D_{1 k6}$	$L_2$	$L_1$
FF 10	8	10	7
FF 12	10	11	8
FF 15	15	13	9
FF 20	20	19	14
FF 25	25	20	15
FF 30	30	21	16

Bezeichnung	$\varnothing D_{1 k6}$	$\varnothing D_{2 k6}$	$L_1$	$L_2$	$L_3$	M1
BK 10	10	8	54	15	31	M10x1
BK 12	12	10	54	15	29	M12x1
BK 15	15	12	60	20	32	M15x1
BK 17	17	15	76	23	40	M17x1
BK 20	20	17	78	25	40	M20x1
BK 25	25	20	95	30	48	M25x1,5
BK 30	30	25	110	38	63	M30x1,5
BK 35	35	30	128	45	73	M35x1,5
BK 40	40	35	148	50	85	M40x1,5

Bezeichnung	$\varnothing D_{1 k6}$	$L_2$	$L_1$
BF 10	8	10	7
BF 12	10	11	8
BF 15	15	13	9
BF 17	17	16	12
BF 20	20	16	12
BF 25	25	20	15
BF 30	30	21	16
BF 35	35	22	17
BF 40	40	23	18