

Bevel gear boxes KRG-NV

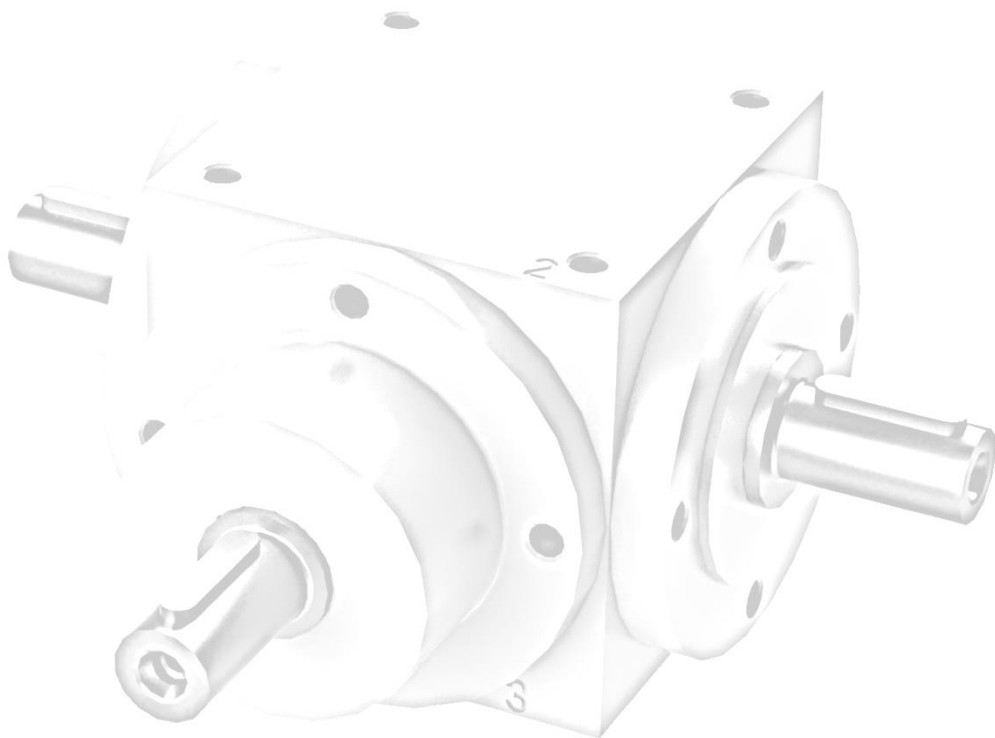

Operating manual

1	Important Information	2
1.1	Instructions on Documentation	2
1.2	Safekeeping of the Documentation	2
1.3	Used Symbols.....	2
1.4	Qualified Staff	2
1.5	General Safety Instructions.....	3
2	Overview of Bevel gear boxes	4
3	Assembly	5
3.1	General Assembly Instructions	5
4	Commissioning	6
5	Maintenance	6
5.1	Lubricants and Fill Quantities.....	7
6	Malfunctions	8
7	Manufacturer’s Declaration	9

1 Important Information

This chapter contains important information on the safe handling of the product and on this operating manual.

1.1 Instructions on Documentation

The following instructions will guide you through the entire documentation.
We assume no liability for damages resulting from non-compliance with this operating manual.
Forward this operating manual to the plant operator so that it is available if needed.

1.2 Safekeeping of the Documentation

Keep this operating manual and all other applicable documents safe so that they are available if needed.

1.3 Used Symbols



Information

Instructions and information on the operation of the Bevel gear boxes



Attention!

Non-compliance may result in material damage and impair the operation of the gear unit.



Warning!

Safety instruction: non-compliance may result in serious or fatal injuries.



QR Barcode

Provides a direct link to the products on our website.
Compatible with QR barcode scanner apps for all Android, Apple and Windows smart phones / tablets.

1.4 Qualified Staff



Qualified staff according to this operating manual refers to specialists who are familiar with the installation, assembly, commissioning and operation of the Bevel gear boxes and the hazards involved and who possess the necessary capabilities on the basis of their specialist training and knowledge of the applicable standards.

1.5 General Safety Instructions

The following warnings, preventive measures and instructions are intended to guarantee your safety and to avoid damage to the gear or the components connected to it. This chapter contains warnings and instructions that generally apply to the handling of the gear.



Intended Use:

The Bevel gear boxes are designed to be installed in machines and are solely intended for the redirection and multiplication of torques.

Please check the torques capacities in our catalog or at www.neff-gewindetriebe.de.

Any other use is considered misuse. The manufacturer assumes no liability for any damage resulting from misuse.

If the device is installed in machines or plants, commissioning is prohibited until it is determined that it complies with the EC machinery directive.



Attention!

This operating manual must be kept close to the device and be easily accessible and available to all users.



Attention!

Risk of damage to the gear resulting from storage and transport.

Correct storage, installation and assembly as well as diligent operation and maintenance are prerequisites for the trouble-free and safe operation of the gear boxes.

The Bevel gear boxes must be protected against mechanical impacts and vibrations during transport and storage.



Warning!

Work on live components:

E.g. installation of drive units must only be carried out by trained electricians.

2 Overview of Bevel gear boxes



Description of Bevel gear boxes:

Neff Bevel gear boxes are used for applications where precise redirection and multiplication of torques are required.

Our standard range comprises 3 models (NV 065 / NV 090 / NV 120). The cubic housing that is machined on 4 sides allows for the installation of motors, gears or pressure transducers. All models are designed to cater position-independent operation.

Basically, 2 different movement principles have to be distinguished:

Version:	Exposition:
A0	
F0	
M0	
B0	
C0	
D0	
G0	
H0	
J0	

3 Assembly

3.1 General Assembly Instructions



The transmissions should always be installed according to the fitting position that has been ordered. The gear unit should be set up on appropriate solid foundations or mounted as a flange drive directly on the machine to be driven. The shaft ends have to be aligned very carefully for quiet running and safety during operation. To compensate for minor mounting inaccuracies we recommend the use of elastic couplings. The couplings must be warm or must be mounted with the aid of D-centring and a screw. Do not hammer! This will avoid damage to the tooth profile, rolling bearings and locking rings.

Plug-in transmissions can be fitted directly onto the shaft of the driven machine. For flange gears it is important that the attachment surface is at exact right angles to the machine shaft's axis. Otherwise the bearings will suffer too much stress and might be damaged.

The reaction torque corresponding to the output torque can be supported with a torque converter bearing. The bar should be mounted on the gears' machine side in order to prevent additional bending stresses. Do not mount the gears directly on a foundation plate when the machine shaft is bedded near the gears. For hollow shafts with a shrunk-on flange, please additionally refer to our assembly instructions for shaft-hub connections.

The tolerances of the four assembly sides correspond to the DIN ISO 2768-mH standard.

Size	NV065	NV 090	NV120
Bolts (min. 8.8)	M6	M8	M10
Length of engagement	12	14	15
Max. torque in Nm	10	25	50

The torques mentioned in the table are only rough and nonbinding guidelines – see VDI 2230.



Attention!

The lubrication nipples must always be accessible during operation.



Attention!

Do not hammer the shaft end or the hollow shaft when aligning the Bevel gear boxes.

4 Commissioning

Prior to commissioning it must be checked whether:

- The lubricant has been filled in
- All bolts/nuts have been tightened and rotating parts have been secured against loosening
- The coupling of the input and output shafts does not generate any impermissible transversal forces or torques
- Monitoring and protective devices must not be bypassed
- If a vent filter was intended it must be checked whether it has been installed

If possible, perform a test run without load, while checking the running noises and temperature development

Caution! Rotating parts may cause hazard

The gearbox temperature must not exceed 90°C unless the value has been coordinated with NEFF.

Caution! Hot surfaces may cause hazards.

In case of abnormal noise or vibrations, discontinue the commissioning and contact the service department. The same applies to gearboxes that were not designed for temperatures above 90°C but that exceed this temperature.



Caution!

- Rotating parts may cause hazards.
 - Hot surfaces may be cause hazards.
 - Check the motor data during the first run.
-

5 Maintenance



All ATEK drives require only a minimum of maintenance. For gearboxes with lifetime lubrication, maintenance is reduced to regular checks for lubricant loss due to leakage, to visual status inspection of the sealings, and temperature measurements if appropriate.

Please note that any warranty claim will expire by opening of the gearboxes. Therefore the gearboxes should only be opened at an ATEK factory or after consent by ATEK.



Caution!

Please note that any warranty claim will expire by opening of the gearboxes

5.1 Lubricants and Fill Quantities



Lubricant typ:

Castrol Alphasyn GS220

Please contact NEFF for technical data sheet or safety data sheet.



Lubrication:

Please observe any guidance notes on the identification plate of the gearbox.

Permanently lubricated gearboxes have been factory-filled with the required lubricant quantity and are maintenance-free under normal operating conditions.

In case of extreme requirements or increased service life demands we recommend an oil change.

Operating temperature: < 60°C lifetime lubrication

Operating temperature: > 60°C and < 90°C oil change after 15,000 h

An oil change will also be required if a larger lubricant amount has escaped due to leakage.

You may inquire the oil quantity and the oil grade from our service. You will need the serial number of the gearbox for this.

Fill quantities:

Special fitting position and higher rpm than 1500 12/min need other fill quantities.

The following can be taken as a rough guidance value of the filling quantity for bevel gearboxes:

The middle of the horizontal shaft.

For standard fitting an rpm 1500 1/min:

Typ	NV 065	NV 090	NV 120
Fill quantities (ml)	70ml	140ml	350ml



In addition to our factory lubricants, other equivalent brand lubricants may also be used.

This only applies if they are compared to the data sheets of the above manufacturers.



To much grease increases friction and therefore causes an increase in temperature.

6 Malfunctions



Service: Should malfunctions occur during operation, first try to identify the manner of the malfunction with the table below and to repair it. If it is a malfunction you can't repair, please contact our technical service (see last page).

Malfunction	Cause	Remedy
Unusual, constant running noises.	<ul style="list-style-type: none"> ➤ Rolling / grinding: Bearing damage ➤ Tapping: Irregularity in gearing 	Check oil fill level. Consult the technical service.
Unusual, irregular running noises.	Foreign object in the oil.	Check oil fill level. Stop drive. Consult the technical service.
Unusually high temperature at the housing.	<ul style="list-style-type: none"> ➤ Not enough oil. ➤ Defective gearing or bearing. 	Check and correct oil filling. Consult the technical service.
oil exists at the shaft seal ring.	Defective sealing.	Consult the technical service.
Oil exists at the shaft seal ring and at the screw.	Too much oil in the gear.	Check and correct oil fill level. Consult the technical service.
The shaft does not turn.	The connection between the driving shaft and the shaft or the gearing is broken.	Have the gear repaired.

7 Manufacturer's Declaration

We hereby declare that the following product:

Bevel gear boxes KRG-NV
Version A0, F0, M0, B0, C0, D0, G0 h0, J0
In the sizes
NV 06 / NV 090 / NV 120
For torques

was manufactured in accordance with the EC machinery directive 2006/42/EC annex II B on incomplete machinery.

This incomplete machinery must not be commissioned until the machine it is to be incorporated in has been declared to comply with the provisions of the EC machinery directive, the harmonized standards, European standards or the applicable national standards.

The manufacturer undertakes to forward the documentation on the incomplete machinery to national authorities on request. The technical documentation was created according to annex VII B.

Person responsible for documentation:

Andreas Ries, Director of quality management

Address of the person responsible for documentation:

Neff Gewindetriebe GmbH
Karl-Benz-Str. 24
71093 Weil im Schönbuch
Germany

The following harmonized standards have been applied:

DIN EN ISO 12100-1 Safety of machinery – Basic concepts, general principles for design, part 1: Basic terminology, methodology

DIN EN ISO 12100-2 Safety of machinery – Basic concepts, general principles for design, part 2: Technical principles and specifications

The following national standards, guidelines and specifications have been applied:

BGV D8 Accident prevention regulations for hoist gears, lifting and towing equipment

Neff Gewindetriebe GmbH
Karl-Benz-Str. 24
71093 Weil im Schönbuch
+49(0)7157/53890-0

