

**Screw Jack M-J / MH-Series
Version N/VK/R**

NEFF
GEWINDETRIEBE

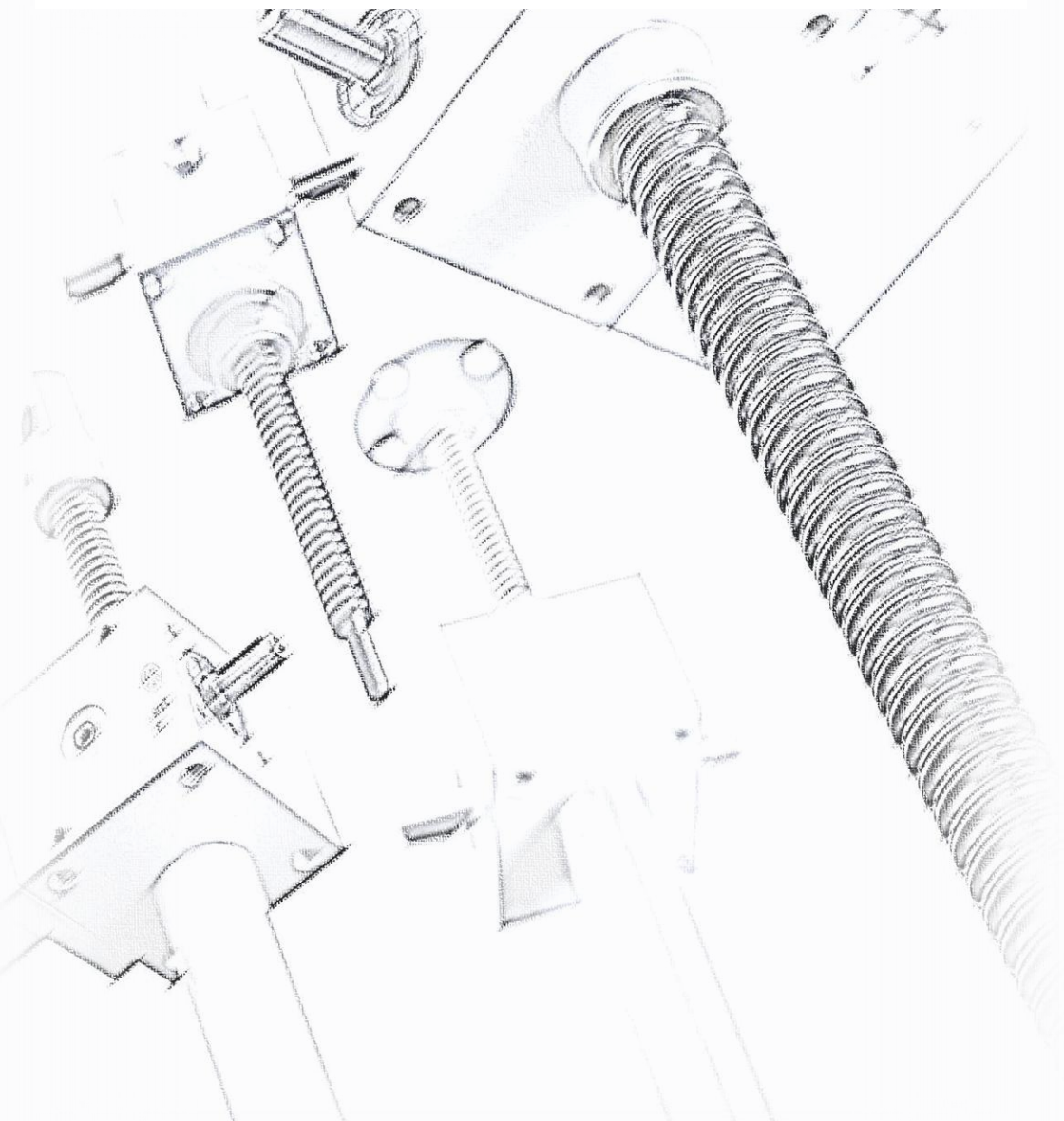

Operating Manual

1	Important Information	2
1.1	Instructions on Documentation	2
1.2	Safekeeping of the Documentation.....	2
1.3	Used Symbols	2
1.4	Qualified Staff	2
1.5	General Safety Instructions	3
2	Overview of the Worm Gear Screw Jacks	4
3	Design of the Worm Gear Screw Jack Type N	5
4	Design of the Worm Gear Screw Jack Type R	6
5	Assembly	7
5.1	General Assembly Instructions.....	7
5.2	Mounting Several Worm Gear Screw Jacks in Parallel	8
5.3	Screw Jacks with safety nut (optional with limit switch)	9
5.4	Screw Jacks with telescopic screw	11
6	Commissioning	12
7	Maintenance	12
7.1	Lubricants and Fill Quantities.....	13
8	Malfunctions	14
9	Manufacturer's Declaration	15

1 Important Information

This chapter contains important information on the safe handling of the product and on this operating manual.

1.1 Instructions on Documentation

The following instructions will guide you through the entire documentation.
We assume no liability for damages resulting from non-compliance with this operating manual.
Forward this operating manual to the plant operator so that it is available if needed.

1.2 Safekeeping of the Documentation

Keep this operating manual and all other applicable documents safe so that they are available if needed.

1.3 Used Symbols



Information

Instructions and information on the operation of the worm gear screw jacks.



Attention!

Non-compliance may result in material damage and impair the operation of the gear unit.



Warning!

Safety instruction: non-compliance may result in serious or fatal injuries.



QR Barcode

Provides a direct link to the products on our website. Compatible with QR barcode scanner apps for all Android, Apple and Windows smart phones / tablets.

1.4 Qualified Staff



Qualified staff according to this operating manual refers to specialists who are familiar with the installation, assembly, commissioning and operation of the worm gear screw jacks and the hazards involved and who possess the necessary capabilities on the basis of their specialist training and knowledge of the applicable standards.

1.5 General Safety Instructions

The following warnings, preventive measures and instructions are intended to guarantee your safety and to avoid damage to the lifting gear or the components connected to it. This chapter contains warnings and instructions that generally apply to the handling of the lifting gear.



Intended Use:

The M0-5 / J1-5 / MH1-MH5 / JH3 worm gear screw jacks are intended only to carry out lifting, lowering, tilting and feeding motions.

Please find lifting capacities in our catalog or at www.neff-gewindetriebe.de.

Any other use is considered misuse. The manufacturer assumes no liability for any damage resulting from misuse.

If the device is installed in machines or plants, commissioning is prohibited until it is determined that it complies with the EC machinery directive.



Attention!

Requirement according to the German accident prevention regulations VBG14 / VBG 70:

If worm gear screw jacks are operated in theatre stages (VBG 70), lifting platforms (VBG 14) or lifting equipment where there is a danger to persons, we generally recommend using a safety nut for fall protection.



Attention!

This operating manual must be kept close to the device and be easily accessible and available to all users.



Attention!

Risk of damage to the lifting gear resulting from storage and transport.

Correct storage, installation and assembly as well as diligent operation and maintenance are prerequisites for the trouble-free and safe operation of the worm gear screw jacks.

The worm gear screw jack must be protected against mechanical impacts and vibrations during transport and storage.



Warning!

Work on live components:

E.g. installation of limit switches or a drive unit must only be carried out by trained electricians.

2 Overview of the Worm Gear Screw Jacks



Description of a Worm Gear Screw Jack:

Neff worm gear screw jacks are used for applications where precise lifting, lowering, tilting and feeding motions are required. Our standard range comprises 17 models (M0-5 / J1-5 / MH1-MH5 / JH3). The cubic housing that is machined on 4 sides allows for the installation of motors, gears or pressure transducers. All models are designed to cater for pressure and tensile loads as well as position-independent operation.

Basically, 2 different movement principles have to be distinguished:

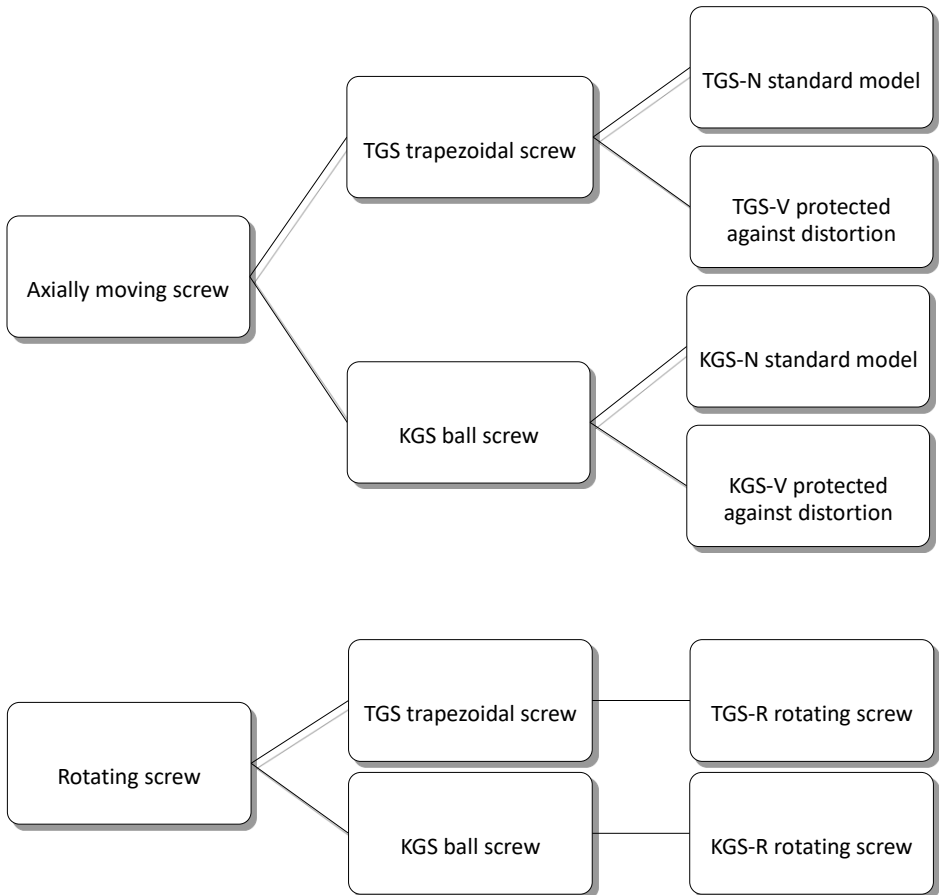

5 Assembly

5.1 General Assembly Instructions



The worm gear screw jack is fastened via the housing or other fastening components (mounting plates or cardan adapters, see QR code below). The housing always needs to be screwed to a machined surface (not to rolled steel profiles or similar) in order to avoid misalignment or noise.

Depending on the respective application, the worm gear screw jack and the screw have to be precisely aligned at a right angle or in parallel to the machine component and tightened during assembly.

The tolerances of the four assembly sides correspond to the DIN ISO 2768-mH standard.

Size	M0	M1 MH1	M2 MH2	M3 MH3	M4 MH4	M5 MH5	J1	J2	J3 JH3	J4	J5
Bolts (min. 8.8)	M6	M8	M8	M10	M12	M20	M2 4	M3 0	M30	M36	M42
Length of engagement	12	13	15	15	16	30	40	45	45	54	80
Max. torque in Nm	10	25	25	50	80	400	73 0	145 0	1450	2600	4000

The torques mentioned in the table are only rough and nonbinding guidelines – see VDI 2230.



Lateral forces have to be absorbed by suitable guiderails; otherwise the device lifecycle would be shortened.



Attention!

The lubrication nipples must always be accessible during operation.



Attention!

Do not hammer the shaft end or the screw when aligning the worm gear screw jack.

QR barcode to Neff fastenings:



QR barcode to Neff attachments:



5.2 Mounting Several Worm Gear Screw Jacks in Parallel

Requirement:

One worm gear screw jack is already installed and fastened as described in chapter 4.



1. Bring the second worm gear screw jack into the planned position, but do not fasten it yet.
2. If rotating screws are used, bring the travelling nuts into the same position.
3. Push the coupling or drive shaft onto the worm gear shaft of the worm gear screw jack that is already fastened.
4. Push the coupling or drive shaft onto the worm gear shaft of the second worm gear screw jack.
5. Fasten the worm gear screw jack.
6. Repeat steps 1-5 with any other gear units.

**Attention!**

Check the sense of rotation of all lifting elements before assembly.

**Attention!**

Use torsionally flexible couplings, drive shafts or cardan shafts in order to compensate for any misalignment of the worm gear screw jackets.

**Attention!**

Observe the lubricating film and screw temperature during run-in. If the screw quickly runs dry (or if there are loud running noises with ball screws) and if the temperature is increased despite observing duty time and permissible power, this indicates impermissible lateral forces.

QR barcode to Neff couplings:



QR barcode to Neff drive shafts:



5.3 Screw Jacks with safety nut (optional with limit switch)

Safety nut acc. to VBG14 or VBG70 requirements only will available on request. If nothing else is specified, our standard safety catch nuts will be delivered. In this connection, the technical data of the safety catch nut always shall be counter-checked against the existing requirements.

i Standard safety nut with trapezoidal or slide thread:

The safety nut will rotate without axial load and thus without any wear with the running nut. At increased wear (trapezoidal or slide thread design), the distance X between both nuts will decrease. At a reduction of 25% of the distance X, the running nut shall be replaced.

For this purpose, the measure X shall be recorded during commissioning and periodically be checked by a maintenance plan.

In case of rupture of the thread turns of the running nut due to increased wear or excessive load, the safety nut will pick up the supported load.

Technical data:

Thread designation:	Value X:	
Trapezoidal thread: Tr12 x X – Tr20 x X	4mm	
Trapezoidal thread: Tr24 x X – 36 x X	5mm	
Trapezoidal thread: Tr40 x X – 50 x X	6mm	
Trapezoidal thread: Tr55 x X – 60 x 9	8mm	
Trapezoidal thread: Tr60 x 12– 100 x 10	9mm	
Trapezoidal thread: Tr100 x 16– 120 x X:	11mm	
Ball thread:	X = Ball Size Dw	
Trapezoidal thread DIN 380 FTTr32-180 x X:	2,5mm	

i Standard safety nut with N/VK Type Gearbox:

With an N/VK type gearbox, the safety nut must be replaced when it is flush with the housing. The distance Y in the lower image corresponds to 25% of the distance X shown above.

Thread designation:	Value Y:	
Trapezoidal thread: Tr12 x X – Tr20 x X	1 mm	
Trapezoidal thread: Tr24 x X – 36 x X	1,2 mm	
Trapezoidal thread: Tr40 x X – 50 x X	1,5 mm	
Trapezoidal thread: Tr55 x X – 60 x 9	2 mm	
Trapezoidal thread: Tr60 x 12– 100 x 10	2,2 mm	
Trapezoidal thread: Tr100 x 16– 120 x X:	2,7 mm	

i Standard safety nut with ball thread:

Safety nuts for ball thread nuts always will be manufactured individually in accordance with the intended use and the ball size.

Normally the ball thread unit will get locked in case of failure and call for attention by an excessive power input.

The safety distance X always will be defined in accordance with the size of the ball.

An optical wear control only will be possible at ball rupture or complete destruction of the deflection pieces.

For this reason, we recommend the integration of a torque supervision in the motor control.

The safety nuts will be dimensioned in accordance with the maximum static load of the ball thread nut and will pick up the load at failure of the nut.

i Standard safety nut with roller tappet limit switch:

Safety nuts with roller tappet limit switch for cases of use when an optical wear check is no longer possible or admissible.

The mechanical roller tappet limit switch shall be connected as forced opener.

The limit switch will be adjustable and should observe a minimum triggering stroke of 2.6 mm.

The limit switch shall be set to the minimum triggering stroke of 2.6 mm and the measure X.

Technical data of roller tappet limit:

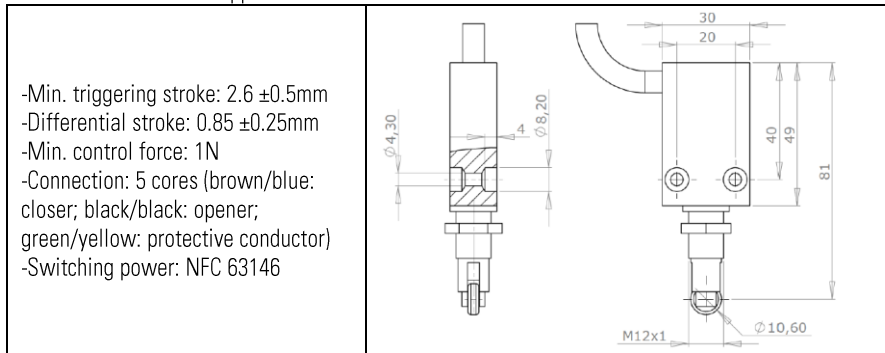

! Attention!

Document optical wear control by maintenance plan.

! Attention!

At the design of the safety nut with limit switch, provide for connection as opener only.

! Attention!

The limit switch only will be present at delivery. Before commissioning, the operating control of the limit switch shall be checked and recorded at simulated nut rupture (reduction of the measure X to 0, or wear of 25% of the measure X).

5.4 Screw Jacks with telescopic screw

NEFF Worm Gear Screw Jacks with telescopic thread spindles are suited to high lifts at simultaneously reduced installation dimensions.
Lateral forces shall be picked up by external telescopic guides.
The number of stages depends on the required installation size and the maximum lifting height.
The stages (only type R-FTr) are marked in the ordering code with e.g. TS4 (4-stage telescopic thread gear). The telescopic thread spindle S-TEG only is available in 2-stage design.

❗ Worm Gear Screw Jacks with multiple stage tubular flat trapezoidal thread spindle R-FTr:

The maintenance of the multiple stage telescopic spindle corresponds to the maintenance intervals for standard trapezoidal spindles RPTS/RATS.

With the single telescopic stages having to be lubricated separately.

A running dry of the single stages must be avoided. Attention has to be paid to the fact that the telescopic stage with the smallest diameter needs a maximum of maintenance.

Technical data of the tubular flat trapezoidal thread spindle R-FTr:

Thread designation:	Outer diameter:	Core diameter:	Pitch:	Material:
FTr 30x32	32mm	22	32mm	1.0503 Oder 1.7225
FTr 60x32	60mm	54	32mm	1.0503
FTr 80x32	80mm	74	32mm	1.0503
FTr 100x32	100mm	94	32mm	1.0503
FTr 120x32	120mm	114	32mm	1.0503
FTr-140x32	140mm	134	32mm	1.0503
FTr-160x32	160mm	154	32mm	1.0503
FTr-180x32	180mm	174	32mm	1.0503

❗ Worm Gear Screw Jacks with synchronous telescopic thread spindle S-TEG:

Design with slide thread unit:

The maintenance of the synchronous telescopic thread spindle S-TEG corresponds to the maintenance intervals for standard trapezoidal thread spindles RPTS/RATS. With the various telescopic stages having to be lubricated separately.

In case the design with safety nut will be used and the latter be active due to a rupture, the unit will be locked by a locking mechanism and must be replaced completely.

6 Commissioning



Attention!

Screw Jack oil filled and with vent valve: Install enclosed vent valve before operation.
Note install position, vent valve must be mounted above the oil level.



Attention!

Check the operation of the limit switch. If possible, start the worm gear screw jack without any load and increase the load slowly.

During commissioning, continuously check the operating temperature, power consumption of the motor and the screw contact pattern.

7 Maintenance



- **With trapezoidal screws, regularly** lubricate the screw.
- **For version VK:** The anti rotating block must be regularly lubricated. Move the Screw Jack to the start position, carefully disout the square pipe plug and lubricate through the recesses in the anti rotating block. Prevent dry running! Recommendation for the interval: check once a month and if necessary relubricate (depending on application)
- **With ball screws (R-Version), observe the following guideline:** lubricate approx. every 200 hours with 1ml per 10mm of screw diameter. For N-Version: Ball screw with lifetime lubrication
- **Approx. 5 operating hours** after commissioning: Retighten all attachment bolts.
- **After approx. 200 operating hours or 1 year** (sooner in tough operating conditions): Check the screw nut for signs of wear and tear.
Clean the screw of old grease and relubricate.
- **NEFF Screw Jacks lifetime-lubricated** if thermal and mechanical limits are met.
- **Disassembly bearing cover:**
 1. Remove the two grub screws at the bearing cover
 2. Take the screw out (remove screw protection if required).
 3. Unscrew the bearing cover.
 4. Remove the old grease.
 5. Refill with new grease.
 6. Strongly press the bearing cover down (3 times the normal contact force).
 7. Loosen the bearing cover again.
 8. Tighten the bearing cover using a defined torque

Type	Torque [Nm]	Type	Torque [Nm]
M0	3	M5	60
M1	5	J1	70
M2	9	J2/J3	150
M3	13	J4	220
M4	32	J5	300

9. Evenly apply the 2 grub screws (use medium-strength threadlocker)



Attention!

When assembling the bearing cover, make sure it fits smoothly and that there is no axial play.



Attention!

Change the screw nut if the axial play exceeds 1/4 of the thread pitch (trapezoidal thread).

7.1 Lubricants and Fill Quantities



Types of factory grease:

Worm gear screw jacks / trapezoidal screws:

NEFF Grease 2

Safety data sheet:



Ball screws:

NEFF Grease 2/3

Safety data sheet:



Screw jacks with oil filling:

AVILUB GEAR RSX-F 320, interchangeable with CLP mineral oil-based gear oils of viscosity class 320.



Fill quantities:

Type	M0	M1 MH1	M2 MH2	M3 MH3	M4 MH4	M5 MH5	J1	J2	J3 JH3	J4	J5
Fill quantities grease in gr.	15	45	70	130	520	1050	1100	1400	1450	2500	5000
Fill quantities oil in gr.	-	50	75	140	370	850	-	-	1000	-	-



In addition to our factory lubricants, other equivalent brand lubricants may also be used.

This only applies if they are compared to the data sheets of the above manufacturers.



Too much grease increases friction and therefore causes an increase in temperature. There is a sufficient amount of lubricant when a small amount of grease begins to exit at the sealing lips.

For screw jacks with an oil filling, the oil level must be set to the midpoint of the sight glass. Reference values can be found in the table.

8 Malfunctions



Service: Should malfunctions occur during operation, first try to identify the manner of the malfunction with the table below and to repair it. If it is a malfunction you can't repair, please contact our technical service (see last page).

Malfunction	Cause	Remedy
Unusual, constant running noises.	<ul style="list-style-type: none"> ➤ Rolling / grinding: Bearing damage ➤ Tapping: Irregularity in gearing 	<p>Check grease fill level. Consult the technical service.</p>
Unusual, irregular running noises.	Foreign object in the grease.	<p>Check grease fill level. Stop drive. Consult the technical service.</p>
Unusually high temperature at the housing.	<ul style="list-style-type: none"> ➤ Not enough grease. ➤ Defective gearing or bearing. 	<p>Check and correct grease filling. Consult the technical service.</p>
Grease or oil exists at the shaft seal ring.	Defective sealing.	Consult the technical service.
Grease or oil exists at the shaft seal ring and at the screw.	Too much grease in the gear.	<p>Check and correct grease fill level. Consult the technical service.</p>
Trapezoidal screw quickly runs dry.	Assembly fault: Impermissible lateral forces.	<p>Repair assembly fault. Consult the technical service.</p>
The worm gear shaft does not turn or the screw turns but does not move although the worm gear shaft is turned.	The connection between the shaft and the hub or the gearing is broken.	Have the gear repaired.

9 Manufacturer's Declaration

We hereby declare that the following product:

Worm gear screw jack, version M-J / MH-JH
with trapezoidal screws or ball screws
model N, R or V
in the sizes
M0-M5, J1-J5, MH1-MH5, JH3
for lifting and lowering loads

was manufactured in accordance with the EC machinery directive 2006/42/EC annex II B on incomplete machinery.

This incomplete machinery must not be commissioned until the machine it is to be incorporated in has been declared to comply with the provisions of the EC machinery directive, the harmonized standards, European standards or the applicable national standards.

The manufacturer undertakes to forward the documentation on the incomplete machinery to national authorities on request. The technical documentation was created according to annex VII B.

Person responsible for documentation:

Andreas Ries, Director of quality management

Address of the person responsible for documentation:

Neff Gewindetribe GmbH
Karl-Benz-Str. 24
71093 Weil im Schönbuch
Germany

The following harmonized standards have been applied:

DIN EN ISO 12100-1 Safety of machinery – Basic concepts, general principles for design, part 1: Basic terminology, methodology

DIN EN ISO 12100-2 Safety of machinery – Basic concepts, general principles for design, part 2: Technical principles and specifications

The following national standards, guidelines and specifications have been applied:

BGV D8 Accident prevention regulations for hoist gears, lifting and towing equipment

Neff Gewindetribe GmbH
Karl-Benz-Str. 24
71093 Weil im Schönbuch
+49(0)7157/53890-0

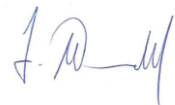

Weil im Schönbuch, 29.08.2012

Hartmut Wandel, Director

Notes: